

## Set-up Procedures for Using Various Type Microphones with the NCS-C250

### 1.0 Introduction

Most any microphone can be used with the NCS-C250 due to the ability to set impedance, level, electret voltage and/or other auxiliary voltages required for certain microphones. Microphones with dynamic or electret elements are most commonly used in communications applications and are the focus of this application note. Additionally, requirements for microphones equipped with preamplifiers and DTMF encoders are discussed.

Before attempting to set-up the NCS-C250 for use with a particular microphone you must have certain key information about the microphone.

- a. Is the microphone terminated in an RJ45 8 pin modular connector? This type connector is required to interface with the NCS-C250.
- b. Wiring diagram of the RJ45 connector
- c. What type microphone element is used? Dynamic or Electret?
- d. Does the microphone require an auxiliary voltage for proper operation?

This information should be detailed in your radio manual or in information supplied with the microphone.

### 2.0 RJ45 Pin Numbering

Unfortunately, there is no standard in the communications industry for the numbering of the RJ45 pins. There are two possibilities for numbering of the RJ45 pins and radio and microphone manufacturers use both. These are shown below.

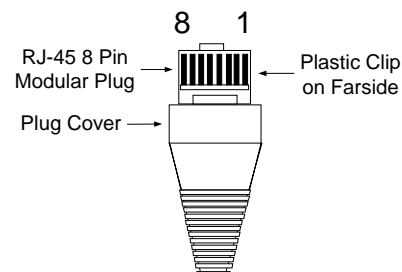
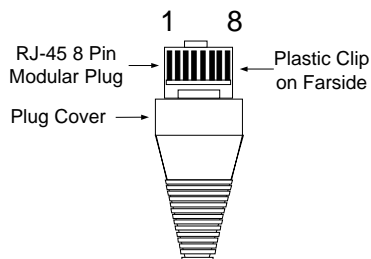

### 2.1 NCS-C250 RJ45 Pin Numbering

The pin numbering of the mic plug and the mic jack used on the NCS-C250 is shown below.

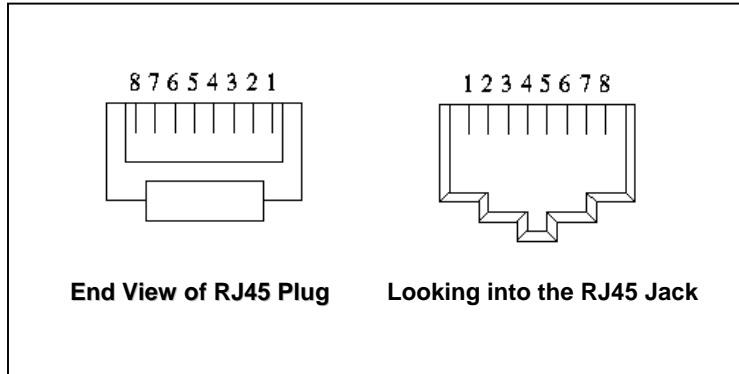

A frequent point of confusion occurs when the microphone to be used with the NCS-C250 is numbered using the opposite convention. The first step is to determine whether your microphone connector is numbered the same as the mic jack of the NCS-C250.

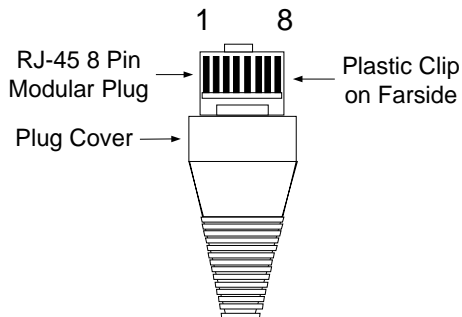

**Pin Numbering Same as  
NCS-C250**

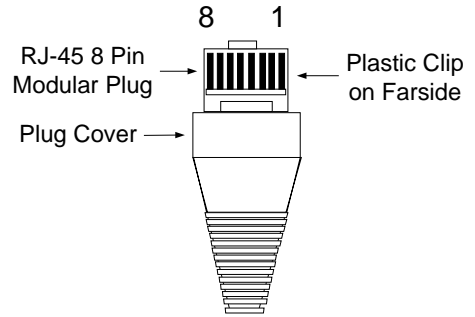

**Pin Numbering Opposite  
to that of NCS-C250**

### 2.2 Determining Pin-outs for Your Microphone

Determining the pin-out for your microphone requires having the necessary pin-out information from the microphone manufacturer. This information should provide a list of the pin assignments and the numbering convention used for the RJ45 connector. Two examples are shown below, the first is of a microphone with an RJ45 connector numbered the same as the NCS-C250 and the second is of a microphone with an RJ45 connector numbered using the opposite convention.

*"All at the Push of a Button"*

**Example of Microphone Connector Numbered Same as the NCS-C250 RJ45 Jack**

Pin #	Function
1	NC
2	NC
3	NC
4	Ground
5	Mic Audio
6	PTT
7	NC
8	NC

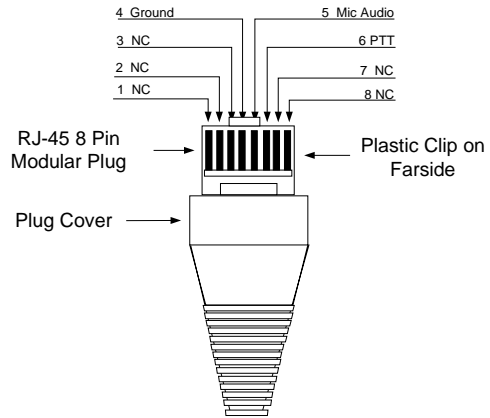

**Example of Microphone Connector Numbered Opposite from that of the NCS-C250 RJ45 Jack**

Pin #	Function
1	NC
2	NC
3	NC
4	Ground
5	Mic Audio
6	PTT
7	NC
8	NC

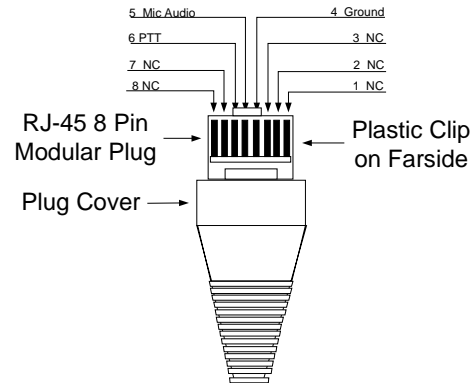

The table of pin assignments is identical to the table in the first example; however, notice that the RJ45 connector numbering is reversed. In order to convert the RJ45 numbering to that used on the NCS-C250 use the following example.

***"All at the Push of a Button"***

Your Microphone Pin Numbering	NCS-C250 Pin Numbering	Microphone Pin Function
1	8	NC
2	7	NC
3	6	NC
4	5	Ground
5	4	Mic Audio
6	3	PTT
7	2	NC
8	1	NC

From the above table, use the “NCS-C250 Pin Numbering” column to determine the proper microphone jumper settings for the NCS-C250

### 3.0 Setting the Microphone Jumpers in the NCS-C250.

The two diagrams below show the proper jumper settings for the two examples given previously. Refer to the NCS-C250 Instruction Manual for additional information on installing these jumpers.

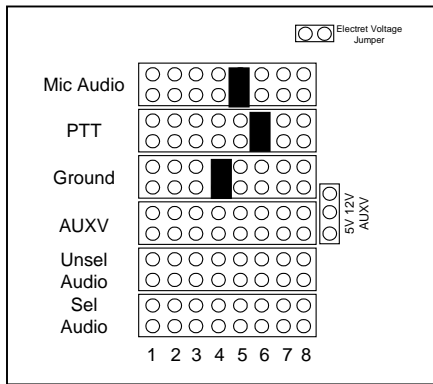

**Jumper Settings for Mic Connector Numbered Same as NCS-C250 Mic Jack**

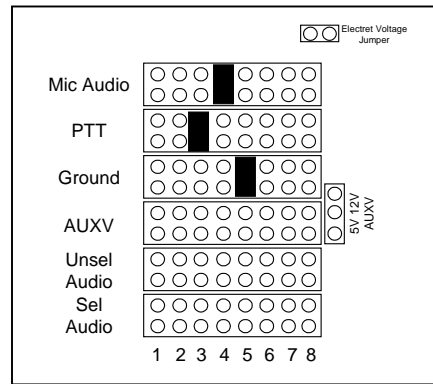

**Jumper Settings for Mic Connector Numbered Opposite from NCS-C250 Mic Jack.**

### 3.1 Electret Microphones

Electret microphones require a “phantom” voltage be applied to the mic audio line. If your microphone is an electret type you must install the electret jumper. See the figure below for placement of the electret jumper. The microphone will not work without this jumper installed. DO NOT install this jumper if your microphone is a dynamic type.

*“All at the Push of a Button”*

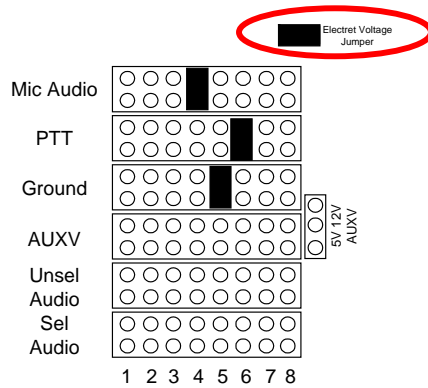

### Jumper Settings for Electret Type Microphone

#### 3.2 DTMF and Preamplified Microphones

If your microphone requires a separate voltage supply to operate a preamp, DTMF keyboard or similar circuitry, a jumper must be installed on the AUXV block at the corresponding microphone pin number. Additionally, you must select the desired voltage, 5V or 12V using a jumper on the AUXV jumper block.

The figure below illustrates the jumper settings for a DTMF microphone that requires a 12 VDC auxiliary voltage to be applied to pin 3 of the RJ45 mic connector.

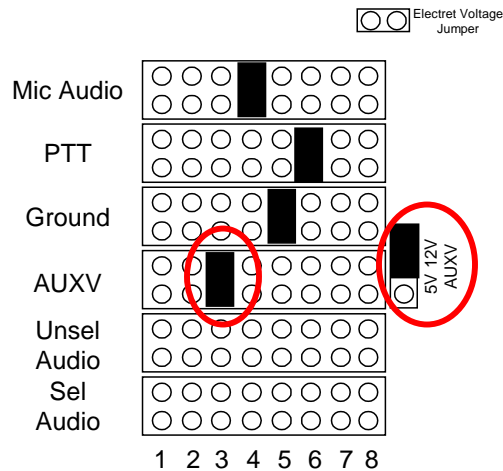

*"All at the Push of a Button"*

#### **4.0 Contact Us**

If you have questions regarding setting up your microphone for use with the NCS-C250, contact NCS at:

Tel/Fax: 888-883-5788

Email: [support@ncsradio.com](mailto:support@ncsradio.com)

***"All at the Push of a Button"***