

## Connecting Radios with Bridge Tied Load (BTL) Audio Outputs to NCS Audio Switching Products

### Introduction

Most commercial 2-way radios are designed with a *Bridge Tied Load (BTL)* audio output. This bridge type circuit is often used in low voltage applications to increase the audio output power to the speaker. On the other hand, most amateur receivers and transceivers provide a *single-ended* audio (speaker) output. Special attention must be given to interfacing BTL outputs to single-ended inputs found on a number of NCS products.

### Single-ended Versus BTL Amplifiers

The two types of amplifiers (single-ended and bridged) are shown schematically below. Notice that one side of the single-ended audio amplifier is grounded while neither side of the BTL amplifier output is grounded. The Speaker-plus and Speaker-minus outputs should **NEVER** be tied to ground. Doing so could result in damage to the BTL output stage of the radio.

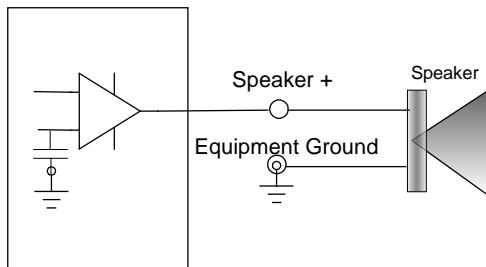

**Single-ended Audio Output**

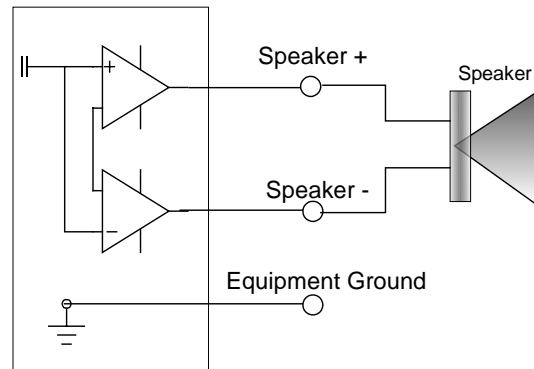

**Bridge Tied Load (BTL) Audio Output**

### Connecting BTL Outputs to Single-ended Inputs

There are two methods of interfacing a BTL audio output to a single-ended input. The more conventional method is to use a transformer to isolate the BTL outputs from the ground of the single-ended input. The other method is to use only half of the BTL output referenced to ground. This method eliminates the need for a transformer.

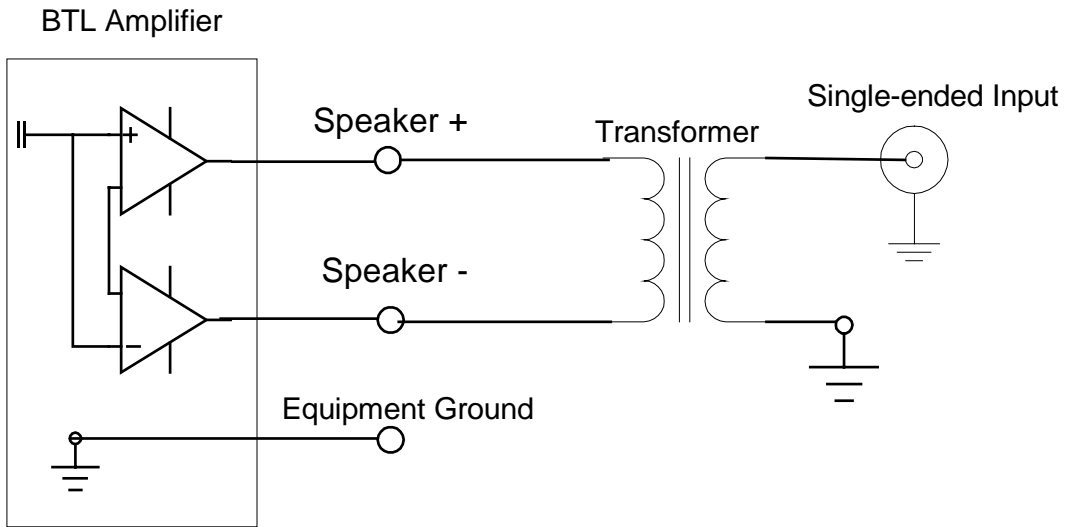

**Transformer Coupled BTL Output to Single-ended Input**

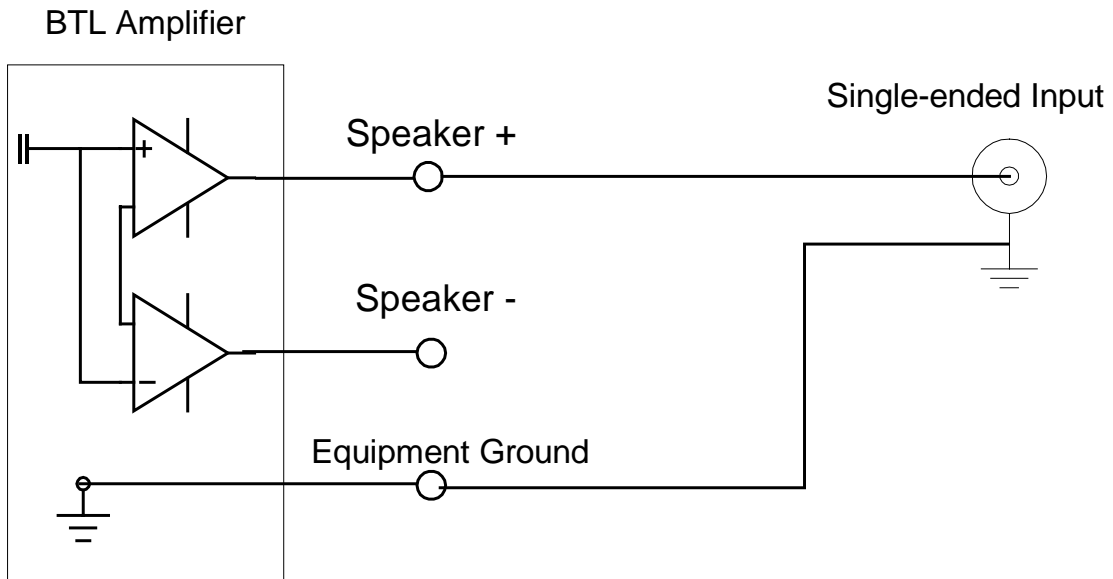

**One-Half BTL Output to Single-ended Input**

**Connecting NCS Products to Radios with BTL Outputs**

The NCS-3203 Multi-Rx II, NCS-3230 Multi-Rx and NCS-C250 Mobile Multi-Switcher all have high impedance single-ended audio inputs. Therefore, when interfacing radios with

*"All at the Push of a Button"*

BTL audio outputs, one of the two methods above must be used to interface the radio's speaker output to the audio input on the listed NCS products.

In the transformer coupled example, a 1:1 audio isolation transformer is used. This transformer can be relatively small since very little power is dissipated in the transformer due to the high impedance input of the NCS products. Any 600 Ohm., 1:1 audio isolation transformer will work for this purpose. A couple of suggested transformers are the Stancor TTPC-8 or the Radio Shack RS 27-1374.

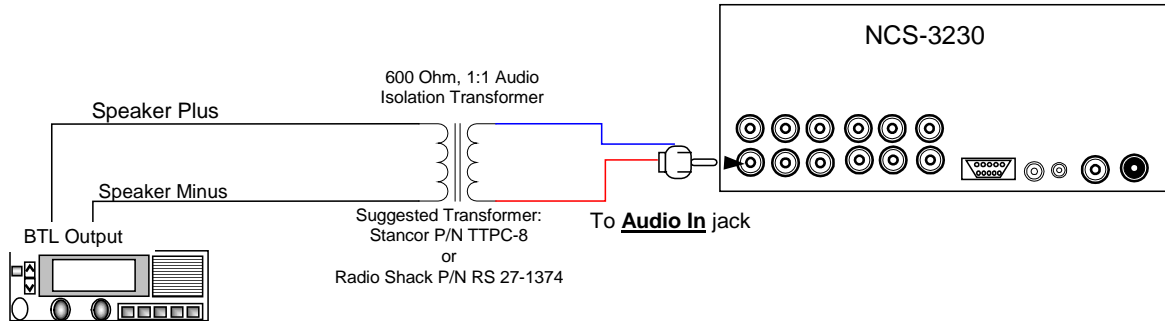

**Example of Connecting a BTL Output to an NCS-3230 Using Audio Isolation Transformer**

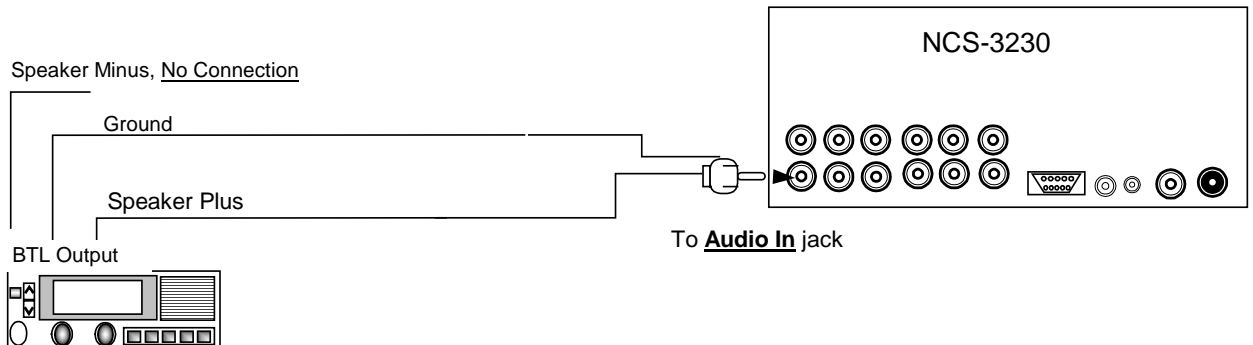

**Example of Connecting a BTL Output to an NCS-3230 Using One-half of the BTL Output**

Please contact NCS for additional information on connecting BTL audio outputs to NCS products.

**NCS Contact Information**

Tel/Fax: 888-883-5788  
Email: [support@ncsradio.com](mailto:support@ncsradio.com)  
URL: [www.ncsradio.com](http://www.ncsradio.com)

*"All at the Push of a Button"*